



(12) **EUROPEAN PATENT APPLICATION**

(43) Date of publication:  
**16.07.2003 Bulletin 2003/29**

(51) Int Cl.7: **G01N 27/49, C12Q 1/00**

(21) Application number: **03007604.6**

(22) Date of filing: **19.06.1996**

(84) Designated Contracting States:  
**AT BE CH DE DK ES FI FR GB GR IE IT LI LU MC  
 NL PT SE**

- Beck, Thomas William  
 South Windsor, New South Wales 2765 (AU)
- Johansen, Oddvar  
 Mulgrave, Victoria 3170 (AU)

(30) Priority: **19.06.1995 AU PN363995**

(74) Representative: **Eyles, Christopher Thomas  
 W.P. THOMPSON & CO.  
 55 Drury Lane  
 London WC2B 5SQ (GB)**

(62) Document number(s) of the earlier application(s) in  
 accordance with Art. 76 EPC:  
**96917287.3 / 0 873 514**

(71) Applicant: **LIFESCAN, INC.  
 Milpitas, California 95035 (US)**

Remarks:  
 This application was filed on 02 - 04 - 2003 as a  
 divisional application to the application mentioned  
 under INID code 62.

(72) Inventors:  
 • **Hodges, Alastair McIndoe  
 Blackburn South, Victoria 3130 (AU)**

(54) **Hollow electrochemical cell**

(57) There is described a hollow electrochemical  
 cell comprising a working electrode (5), a counter elec-

trode (6), and an opening (31) for admitting an analyte  
 to the cell, the working electrode (5) being spaced from  
 the counter electrode (6) by less than 500 µm.

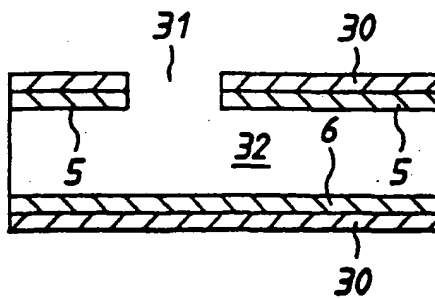

**FIG. 12**

**BEST AVAILABLE COPY**

**Description****FIELD OF THE INVENTION**

[0001] This invention relates to a biosensor and more particularly to an electrochemical biosensor for determining the concentration of an analyte in a carrier. The invention is particularly useful for determining the concentration of glucose in blood and is described herein with reference to that use but it should be understood that the invention is applicable to other analytic determinations.

**BACKGROUND OF THE INVENTION**

[0002] Electrochemical biosensors generally comprise a cell having a working electrode, a counter electrode and a reference electrode. Sometimes the function of the counter and reference electrodes are combined in a single electrode called a "counter/reference" electrode or "pseudo reference electrode". As herein used the term "counter electrode" includes a counter/reference electrode where the context so admits.

[0003] The sample containing the analyte is brought into contact with a reagent containing an enzyme and a redox mediator in the cell. Either the mediator is reduced (receives at least one electron) while the analyte is oxidised (donates at least one electron) or visa versa. Usually it is the analyte which is oxidised and the mediator which is reduced. The invention will be herein described principally with reference to that system but it is also applicable to systems in which the analyte is reduced and the mediator oxidised.

[0004] Electrochemical glucose analysers such as those used by diabetics to monitor blood glucose levels or such as are used in clinics and hospitals are commonly based upon the use of an enzyme such as glucose oxidase dehydrogenase (GOD) and a redox mediator such as a ferricyanide or ferrocyanide. In such prior art system, the sample (e.g. blood) containing the analyte (e.g. glucose) is brought into contact with the reagents in the cell. Glucose is oxidised to gluconic acid and the glucose oxidase is thereby reduced. The mediator then re-oxidizes the glucose oxidase and is reduced in the process. The reduced mediator is then re-oxidized when it transfers electrons to the working electrode. After allowing passage of a predetermined time, sufficient to obtain an accurate estimate of the Faraday current, the concentration of glucose is estimated from the magnitude of the current or voltage signal then measured.

[0005] Prior art electrochemical cells consist of two (or three) adjacent electrodes spaced apart on one side of an insulator and adapted for connection to a measuring device. A target area on which the blood sample is placed is defined on or between the electrodes. Copending Application PCT/AU95/00207 describes a cell in which electrodes are disposed on opposite sides of a porous membrane, one of the electrodes having a liquid

permeable target area.

[0006] In the prior art there is a need to separate the working electrode from the counter (or counter/reference) electrode by a sufficient distance to avoid products of electrochemical reaction at one electrode from interfering with those at the other. In practice a separation of the electrodes of more than 500  $\mu\text{m}$  is required to achieve acceptable accuracy.

[0007] Each batch of cells is required to have been previously calibrated and leads to inaccuracies during use because of variations within the batch, in sample composition, and in ambient conditions.

[0008] It is desired to improve the accuracy and reliability of such biosensors. Achievement of these objectives is made difficult in the case of sensors intended to determine the concentration of analytes in blood because blood contains dissolved gases, ions, colloids, complex micelles, small scale cellular debris, and living cellular components in a predominantly aqueous medium. Any of these may interfere in the determination. Existing sensors are also susceptible to influence from other interfering substances that may be present in the sample and which may be oxidised at the working electrode and mistakenly identified as the analyte of interest. Alternatively, the interfering substances may reduce the oxidised form of the redox mediator. These effects will give artificially elevated estimates of the analyte concentration. Additionally there is always some reduced redox mediator present before the analyte is added and its concentration needs to be known and subtracted from the measured value of reduced mediator to give an accurate concentration of the analyte. Moreover, oxygen in the blood may act as a redox mediator for glucose oxidase dehydrogenase (GOD) in competition with ferrocyanide. Thus high oxygen concentrations can lead to low estimates of glucose concentration. In addition the measurements are sensitive to factors such as changes in humidity, temperature, solution viscosity and haematocrit content.

**OBJECT OF THE INVENTION**

[0009] It is an object of the present invention to provide a method of analysis and apparatus for use in the method which avoid or ameliorate at least some of the disadvantages of the prior art. It is an object of preferred forms of the invention to provide a biosensor of improved accuracy, and/or reliability and/or speed and a method for its use.

**DISCLOSURE OF THE INVENTION**

[0010] According to one aspect the invention consists in a method for determining the concentration of a reduced (or oxidised) form of a redox species in an electrochemical cell of the kind comprising a working electrode and a counter electrode spaced from the working electrode by a predetermined distance, said method

comprising the steps of:

- (1) applying an electric potential difference between the electrodes,
- (2) selecting the potential of the working electrode such that the rate of electro-oxidation of the reduced form (or electro-reduction of the oxidised form) of the species is diffusion controlled,
- (3) selecting the spacing between the working electrode and the counter electrode so that reaction products from the counter electrode arrive at the working electrode,
- (4) determining current as a function of time after application of the potential and prior to achievement of a steady state,
- (5) estimating the magnitude of the steady state current, and
- (6) obtaining from the change in current with time and the magnitude of the steady state current, a value indicative of the diffusion coefficient and/or of the concentration of the reduced form (or the oxidised form) of the species.

**[0011]** The concentration measured in this way is substantially independent of variation if any in the diffusion coefficient of the reduced form, and therefore is compensated for variations in temperature and viscosity. The concentration so measured is independent of variations in haematocrit and other substances which affect the diffusion coefficient of the reduced form of the redox species.

**[0012]** It will be appreciated that the method of the invention is equally applicable for determining the concentration of a reduced form of a redox species or an oxidized form of a redox species in the cell. In the case that the concentration of the reduced form is to be determined the potential of the working electrode must be maintained such that the rate of electro oxidation of the reduced form is diffusion controlled in step (2) and it is the concentration of the reduced form that is obtained in step (5). In the case that the concentration of oxidized form is to be determined, the potential of the working electrode must be maintained such that the rate of electro reduction of the oxidized form is diffusion controlled in step (2) and it is the concentration of the oxidized form that is obtained in step (5).

**[0013]** The redox species may be an analyte or may be a redox mediator.

**[0014]** In preferred embodiments of the method a mediator is used and the concentration of the reduced (or oxidized) form of the mediator is in turn indicative of the concentration of an analyte and a measure of the diffusion coefficient of the reduced (or oxidized) form of the mediator is determined as a precursor to the determination of the concentration of the analyte.

**[0015]** For preference the cell comprises a working electrode and counter/reference electrode. If a reference electrode separate from a counter electrode is

used, then the reference electrode may be in any convenient location in which it is in contact with the sample in the sensor.

**[0016]** In contrast to prior art, when conducting the method of the invention, the electrodes are sufficiently close that the products of electrochemical reaction at the counter electrode migrate to the working electrode during the period of the test. For example, in an enzyme ferricyanide system, the ferrocyanide produced at the counter electrode diffuses to the working electrode.

**[0017]** This allows a steady state concentration profile to be achieved between the electrodes leading to a steady state current. This in turn allows the diffusion coefficient and concentration of the redox species (mediator) to be measured independently of sample variations and therefore greatly improves accuracy and reliability.

**[0018]** The method also permits the haematocrit concentration of blood to be determined from the diffusion coefficient by use of look-up tables (or by separation of red cells from plasma and measurement of the diffusion coefficient of the red cell fraction) and the plasma fraction, and comparing the two.

**[0019]** According to a second aspect, the invention consists in apparatus for determining the concentration of a redox species in an electrochemical cell comprising:

an electrochemical cell having a working electrode and a counter (or counter/reference) electrode, means for applying an electric potential difference between said electrodes, means for measuring the change in current with time, and characterised in that the working electrode is spaced from the counter electrode by less than 500  $\mu\text{m}$ .

**[0020]** In preferred embodiments the cell has an effective volume of 1.5 microlitres or less. Apparatus for use in the invention may comprise a porous membrane, a working electrode on one side of the membrane, a counter/reference electrode on the other side, said electrodes together with a zone of the membrane therebetween defining an electrochemical cell, and wherein the membrane extends laterally from the cell to a sample deposition area spaced apart from the cell zone by a distance greater than the thickness of the membrane.

**[0021]** Preferably the porous membrane, the distance of the target area from the cell portion, and the membrane thickness are so selected in combination that when blood (comprising plasma and red cells) is placed on the target area a plasma front diffuses laterally towards the electrochemical cell zone in advance of the red cells.

**[0022]** It is thus possible to fill a thin layer electrochemical cell with plasma substantially free of haematocrit which would cause a variation in the diffusion coefficient of the redox mediator and which would affect the accuracy of the test as hereinafter explained.

**[0023]** In preferred embodiments of the biosensor according to the invention a second electrochemical cell zone of the membrane is defined by a second working electrode and a second counter/reference electrode on the opposite side of the membrane from the second working electrode. The second electrochemical cell zone is situated intermediate the first cell zone and the sample deposition or "target" area, or is situated on the side of the target area remote from the first electrochemical zone. In these embodiments the plasma comes into contact with enzyme in, or on route to, the first electrochemical cell while plasma reaching the second cell does not. The first cell thus in use measures the concentration of reduced mediator in the presence of plasma (including electrochemically interfering substances), and enzyme while the second electrochemical cell measures it in the presence of plasma (including electrochemically interfering substances) and in the absence of enzyme. This allows determination of the concentration of the reduced interfering substances in the second cell and the concentration of reduced interfering substances plus analyte in the first cell. Subtraction of the one value from the other gives the absolute concentration of analyte.

**[0024]** In a highly preferred embodiment of the invention a hollow cell is employed wherein the working and reference (or counter/reference) electrodes are spaced apart by less than 500  $\mu\text{m}$  and preferably by from 20 - 200  $\mu\text{m}$ .

#### DESCRIPTION OF THE DRAWINGS

**[0025]** The invention will now be more particularly described by way of example only with reference to the accompanying drawings wherein:

Figure 1 is a schematic drawing (not to scale) of a first embodiment according to the invention shown in side elevation.

Figure 2 shows the embodiment of Figure 1 in plan, viewed from above.

Figure 3 shows the embodiment of Figure 1 in plan, viewed from below.

Figure 4 shows the embodiment of Figure 1 viewed in end elevation.

Figure 5 is a schematic drawing (not to scale) of a second embodiment according to the invention in side elevation.

Figure 6 shows the embodiment of Figure 5 in plan, viewed from above.

Figure 7 is a schematic drawing (not to scale) of a third embodiment according to the invention, in side elevation.

Figure 8 shows the embodiment of Figure 7 in plan, viewed from above.

Figure 9 is a schematic drawing (not to scale) according to the invention in plan view, viewed from above.

Figure 10 shows the embodiment of Figure 9 in end elevation.

Figure 11 shows the embodiment of Figure 9 in side elevation.

Figure 12 shows a schematic drawing (not to scale) of a hollow cell embodiment according to the invention, viewed in cross section.

Figure 13 is a graph showing a plot of current (ordinate axis) versus time (coordinate axis) during conduct of a method according to the invention.

Figure 14 is a further graph of use in explaining the method of the invention.

In Figures 5 to 12, components corresponding in function to components of the embodiment of Figures 1 to 4 are identified by identical numerals or indicia.

#### DESCRIPTION OF PREFERRED EMBODIMENTS

**[0026]** With reference to Figures 1 to 4 there is shown a first embodiment of apparatus of the invention, in this case a biosensor for determining glucose in blood. The embodiment comprises a thin strip membrane 1 having upper and lower surfaces 2, 3 and having a cell zone 4 defined between a working electrode 5 disposed on upper surface 2 and a counter electrode 6 disposed on lower surface 3. The membrane thickness is selected so that the electrodes are separated by a distance "I" which is sufficiently close that the products of electrochemical reaction at the counter electrode migrate to the working electrode during the time of the test and a steady state diffusion profile is substantially achieved. Typically, "I" will be less than 500  $\mu\text{m}$ . A sample deposition or "target" area 7 defined on upper surface 2 of membrane 1 is spaced at a distance greater than the membrane thickness from cell zone 4. Membrane 1 has a diffusion zone 8 extending between target area 7 and cell zone 4. A suitable reagent including a redox mediator "M", an enzyme "E" and a pH buffer "B" are contained within cell zone 4 of the membrane and/or between cell zone 4 and target area 7. The reagent may also include stabilisers and the like.

**[0027]** In some cases it is preferable to locate the enzyme and mediator and/or the buffer in different zones of the membrane. For example the mediator may be initially located within electrochemical cell zone 4 while the enzyme may be situated below target area 7 or in diffusion zone 8.

**[0028]** Haemoglobin releases oxygen at low pH's, but at higher pH's it binds oxygen very firmly. Oxygen acts as a redox mediator for glucose oxidase dehydrogenase (GOD). In a glucose sensor this competes with the redox mediator leading to low estimates of glucose concentration. Therefore if desired a first pH buffer can be contained in the vicinity of target area 7 to raise the pH to such a level that all the oxygen is bound to haemoglobin. Such a pH would be non-optimal for GOD/glucose kinetics and would consequently be detrimental to the

speed and sensitivity of the test. In a preferred embodiment of the invention a second pH buffer is contained as a reagent in the vicinity of the working electrode to restore the pH to kinetically optimal levels. The use of a second buffer does not cause oxygen to be released from the haemoglobin as the haemoglobin is contained within the blood cells which are retained near blood target area 7 or are retarded in diffusion in comparison with the plasma and therefore not influenced by the second buffer. In this manner oxygen interference may be greatly reduced or eliminated.

[0029] In use of the sensor a drop of blood containing a concentration of glucose to be determined is placed on target zone 7. The blood components wick towards cell zone 4, the plasma component diffusing more rapidly than red blood cells so that a plasma front reaches cell zone 4 in advance of blood cells.

[0030] When the plasma wicks into contact with the reagent, the reagent is dissolved and a reaction occurs that oxidises the analyte and reduces the mediator. After allowing a predetermined time to complete this reaction an electric potential difference is applied between the working electrode and the counter electrode. The potential of the working electrode is kept sufficiently anodic such that the rate of electro oxidation of the reduced form of the mediator at the working electrode is determined by the rate of diffusion of the reduced form of the mediator to the working electrode, and not by the rate of electron transfer across the electrode/solution interface.

[0031] In addition the concentration of the oxidised form of the mediator at the counter electrode is maintained at a level sufficient to ensure that when a current flows in the electrochemical cell the potential of the counter electrode, and thus also the potential of the working electrode, is not shifted so far in the cathodic direction that the potential of the working electrode is no longer in the diffusion controlled region. That is to say, the concentration of the oxidized form at the counter electrode must be sufficient to maintain diffusion controlled electro oxidation of the reduced form of the mediator at the working electrode.

[0032] The behaviour of a thin layer cell is such that if both oxidised and reduced forms of the redox couple are present, eventually a steady state concentration profile is established across the cell. This results in a steady state current. It has been found that by comparing a measure of the steady state current with the rate at which the current varies in the current transient before the steady state is achieved, the diffusion coefficient of the redox mediator can be measured as well as its concentration.

[0033] More specifically, by solving the diffusion equations for this situation it can be shown that over a restricted time range a plot of  $\ln(i/i_{\infty} - 1)$  vs time (measured in seconds) is linear and has a slope (denoted by S) which is equal to  $-4\pi^2 D/t^2$ , where "i" is the current at time "t", " $i_{\infty}$ " is the steady state current, "D" is the diffu-

sion coefficient in  $\text{cm}^2/\text{sec}$ , "l" is the distance between the electrodes in cm and " $\pi$ " is approximately 3.14159. The concentration of reduced mediator present when the potential was applied between the electrodes is given by  $2\pi^2 i_{\infty} / FAS$ , where "F" is Faraday's constant, A is the working electrode area and the other symbols are as given above. As this later formula uses S it includes the measured value of the diffusion coefficient.

[0034] Since l is a constant for a given cell, measurement of i as a function of time and  $i_{\infty}$  enable the value of the diffusion coefficient of the redox mediator to be calculated and the concentration of the analyte to be determined.

[0035] Moreover the determination of analyte concentration compensates for any variation to the diffusion coefficient of the species which is electro oxidised or electro reduced at the working electrode. Changes in the value of the diffusion coefficient may occur as a result of changes in the temperature and viscosity of the solution or variation of the membrane permeability. Other adjustments to the measured value of the concentration may be necessary to account for other factors such as changes to the cell geometry, changes to the enzyme chemistry or other factors which may effect the measured concentration. If the measurement is made on plasma substantially free of haematocrit (which if present causes variation in the diffusion coefficient of the redox mediator) the accuracy of the method is further improved.

[0036] Each of electrodes 5,6 has a predefined area. In the embodiments of Figures 1 to 4 cell zone 4 is defined by edges 9, 10, 11 of the membrane which correspond with edges of electrodes 5, 6 and by leading (with respect to target area 7) edges 12, 13 of the electrodes. In the present example the electrodes are about 600 angstrom thick and are from 1 to 5 mm wide.

[0037] Optionally, both sides of the membrane are covered with the exception of the target area 7 by laminating layers 14 (omitted from plan views) which serves to prevent evaporation of water from the sample and to provide mechanical robustness to the apparatus. Evaporation of water is undesirable as it concentrates the sample, allows the electrodes to dry out, and allows the solution to cool, affecting the diffusion coefficient and slowing the enzyme kinetics, although diffusion coefficient can be estimated as above.

[0038] A second embodiment according to the invention, shown in Figures 5 and 6, differs from the first embodiment by inclusion of a second working electrode 25 and counter/reference electrode 26 defining a second cell zone 24 therebetween. These electrodes are also spaced apart by less than 500  $\mu\text{m}$  in the present example. Second electrodes 25, 26 are situated intermediate cell zone 4 and target area 7. In this embodiment the redox mediator is contained in the membrane below or adjacent to target area 7 or intermediate target area 7 and first cell zone 4. The enzyme is contained in the membrane in the first cell zone 4 and second cell zone

24. The enzyme does not extend into second cell 24. In this case when blood is added to the target area, it dissolves the redox mediator. This wicks along the membrane so that second electrochemical cell 24 contains redox mediator analyte and serum including electrochemically interfering substances. First electrochemical cell receives mediator, analyte, serum containing electrochemically interfering substances, and enzyme. Potential is now applied between both working electrodes and the counter electrode or electrodes but the change in current with time is measured separately for each pair. This allows the determination of the concentration of reduced mediator in the absence of analyte plus the concentration of electrochemically interfering substances in the second electrochemical cell and the concentration of these plus analyte in the first electrochemical cell. Subtraction of the one value from the other gives the absolute concentration of analyte.

[0039] The same benefit is achieved by a different geometry in the embodiment of Figures 7 and 8 in which the second working electrode and second counter/reference electrode define the second cell 24 on the side of target area 7 remote from first electrochemical cell 4. In this case the enzyme may be contained in the membrane strip between the target area and cell 1. The redox mediator may be in the vicinity of the target area or between the target area and each cell. The diffusion coefficient of mediator is lowered by undissolved enzyme and the arrangement of Figures 7 and 8 has the advantage of keeping enzyme out of the thin layer cells and allowing a faster test (as the steady state current is reached more quickly). Furthermore the diffusion constant of redox mediator is then the same in both thin layer cells allowing more accurate subtraction of interference.

[0040] Although the embodiments of Figures 1 to 8 are unitary sensors, it will be understood that a plurality of sensors may be formed on a single membrane as shown in the embodiment of Figures 9 to 11. In this case the electrodes of one sensor are conductively connected to those of an adjacent sensor. Sensors may be used successively and severed from the strip after use.

[0041] In the embodiment of Figures 9 to 11 electrode dimensions are defined in the diffusion direction (indicated by arrow) by the width of the electrode in that direction. The effective dimension of the electrode in a direction transverse to diffusion direction is defined between compressed volumes 16 of the membrane in a manner more fully described in co-pending Application PCT/AU96/00210, the disclosure of which is incorporated herein by reference in its entirety. For clarity optional laminated layer 14 of Figure 1 has been omitted from Figures 9 to 11.

[0042] In the embodiment of Figure 12 there is shown a hollow cell according to the invention wherein the electrodes 5,6 are supported by spaced apart polymer walls 30 to define a hollow cell. An opening 31 is provided on one side of the cell whereby a sample can be admitted

into cavity 32. In this embodiment a membrane is not used. As in previous embodiments, the electrodes are spaced apart by less than 500  $\mu\text{m}$ , preferably 20 - 400  $\mu\text{m}$  and more preferably 20 - 200  $\mu\text{m}$ . Desirably the effective cell volume is 1.5 microlitres or less.

[0043] It will be understood that the method of the invention may be performed with a cell constructed in accord with co-pending application PCT/AU95/00207 or cells of other known design, provided these are modified to provide a sufficiently small distance between electrode faces.

[0044] The method of the invention will now be further exemplified with reference to figures 13 and 14.

#### 15 EXAMPLE 1

[0045] A membrane 130 microns thick was coated on both sides with a layer of Platinum 60 nanometers thick. An area of 12.6 sq. mm was defined by compressing the membrane. 1.5 microlitres of a solution containing 0.2 Molar potassium ferricyanide and 1% by weight glucose oxidase dehydrogenase was added to the defined area of the membrane and the water allowed to evaporate.

[0046] The platinum layers were then connected to a potentiostat to be used as the working and counter/reference electrodes. 3.0 microlitres of an aqueous solution containing 5 millimolar D-glucose and 0.9 wt % NaCl was dropped on to the defined area of the membrane. After an elapse of 20 seconds a voltage of 300 millivolts was applied between the working and counter/reference electrodes and the current recorded for a further 30 seconds at intervals of 0.1 seconds.

[0047] Figure 13 is a graph of current versus time based on the above measurements. Using a value of the steady state current of 26.9 microamps the function  $\ln(i/26.9 - 1)$  was computed and plotted versus time. The slope of the graph (Figure 14) is -0.342 which corresponds to a diffusion coefficient of  $1.5 \times 10^{-6} \text{ cm}^2$  per second and a corrected glucose concentration (subtracting background ferrocyanide) of 5.0 millimolar.

[0048] The steady state current is one in which no further significant current change occurs during the test. As will be understood by those skilled in the art, a minimum current may be reached after which there may be a drift due to factors such as lateral diffusion, evaporation, interfering electrochemical reactions or the like. However, in practice it is not difficult to estimate the "steady state" current ( $i^{\infty}$ ). One method for doing so involves approximating an initial value for  $i^{\infty}$ . Using the fit of the  $i$  versus  $t$  data to the theoretical curve a better estimate of  $i^{\infty}$  is then obtained. This is repeated reiteratively until the measured value and approximated value converge to within an acceptable difference, thus yielding an estimated  $i^{\infty}$ .

[0049] In practice, the measurements of current  $i$  at time  $t$  are made between a minimum time  $t_{\text{min}}$  and a maximum time  $t_{\text{max}}$  after the potential is applied. The minimum and maximum time are determined by the ap-

plicability of the equations and can readily be determined by experiment of a routine nature. If desired the test may be repeated by switching off the voltage and allowing the concentration profiles of the redox species to return towards their initial states.

[0050] It is to be understood that the analysis of the current v. time curve to obtain values of the Diffusion Co-efficient and/or concentration is not limited to the method given above but could also be achieved by other methods.

[0051] For instance, the early part of the current v. time curve could be analysed by the Cottrell equation to obtain a value of  $D^{1/2} \times Co$  ( $Co$  = Concentration of analyte) and the steady state current analysed to obtain a value of  $D \times Co$ . These 2 values can then be compared to obtain  $D$  and  $C$  separately.

[0052] It will be understood that in practice of the invention an electrical signal is issued by the apparatus which is indicative of change in current with time. The signal may be an analogue or digital signal or may be a series of signals issued at predetermined time intervals. These signals may be processed by means of a micro-processor or other conventional circuit to perform the required calculations in accordance with stored algorithms to yield an output signal indicative of the diffusion coefficient, analyte concentration, haematocrit concentration or the like respectively. One or more such output signals may be displayed by means of an analogue or digital display.

[0053] It is also possible by suitable cell design to operate the cell as a depletion cell measuring the current required to deplete the mediator. For example in the embodiment of Figure 5 the method of the invention may be performed using electrodes 5, 6, which are spaced apart by less than 500  $\mu\text{m}$ . An amperometric or voltammetric depletion measurement may be made using electrodes 5 and 26 which are spaced apart more than 500  $\mu\text{m}$  and such that there is no interference between the redox species being amperometrically determined at electrodes 5, 26.

[0054] The depletion measurement may be made prior to, during or subsequent to, the measurement of diffusion coefficient by the method of the invention. This enables a substantial improvement in accuracy and reproducibility to be obtained.

[0055] In the embodiments described the membrane is preferably an asymmetric porous membrane of the kind described in Patent No. 4,629,563 and 4,774,039 both of which are incorporated herein in their entirety by reference. However symmetrical porous membranes may be employed. The membrane may be in the form of a sheet, tube, hollow fibre or other suitable form.

[0056] If the membrane is asymmetric the target area is preferably on the more open side of the asymmetric membrane. The uncompressed membrane desirably has a thickness of from 20 to 500  $\mu\text{m}$ . The minimum thickness is selected having regard to speed, sensitivity, accuracy and cost. If desired a gel may be employed to

separate haematocrit from GOD. The gel may be present between the electrodes and/or in the space between the sample application area and the electrodes.

[0057] The working electrode is of any suitable metal for example gold, silver, platinum, palladium, iridium, lead, a suitable alloy. The working electrode may be preformed or formed in situ by any suitable method for example sputtering, evaporation under partial vacuum, by electrodeless plating, electroplating, or the like. Suitable non-metal conductors may also be used for electrode construction. For example, conducting polymers such as poly(pyrrole), poly(aniline), porphyrin "wires", poly(isoprene) and poly(cis-butadiene) doped with iodine and "ladder polymers". Other non-metal electrodes may be graphite or carbon mixed with a binder, or a carbon filled plastic. Inorganic electrodes such as  $\text{In}_2\text{O}_3$  or  $\text{SnO}_2$  may also be used. The counter/reference electrode may for example be of similar construction to the working electrode. Nickel hydroxide or a silver halide may also be used to form the counter/reference electrode. Silver chloride may be employed but it will be understood that chloridisation may not be necessary and silver may be used if sufficient chloride ions are present in the blood sample. Although in the embodiments described the working electrode is shown on the upper surface of the biosensor and the counter/reference electrode is on the lower surface, these may be reversed.

[0058] It is preferable that the working electrode and counter (or counter/reference) electrodes are of substantially the same effective geometric area.

[0059] If a separate reference and counter electrode are employed, they may be of similar construction. The reference electrode can be in any suitable location.

[0060] It will be understood that the features of one embodiment hereindescribed may be combined with those of another. The invention is not limited to use with any particular combination of enzyme and mediator and combinations such as are described in EP 0351892 or elsewhere may be employed. The system may be used to determine analytes other than glucose (for example, cholesterol) by suitable adaptation of reagents and by appropriate membrane selection. The system may also be adapted for use with media other than blood. For example the method may be employed to determine the concentration of contaminants such as chlorine, iron, lead, cadmium, copper, etc., in water.

[0061] Although the cells herein described have generally planar and parallel electrodes it will be understood that other configurations may be employed, for example one electrode could be a rod or needle and the other a concentric sleeve.

[0062] It will be apparent to those skilled in the art from the disclosure hereof the invention may be embodied in other forms without departing from the inventive concept herein disclosed.

[0063] Features which appear herein include:

1. A method for determining the concentration of a

reduced (or oxidised) form of a redox species in an electrochemical cell of the kind comprising a working electrode and a counter electrode spaced from the working electrode by a predetermined distance, said method comprising the steps of:

- (1) applying an electric potential difference between the electrodes,
  - (2) selecting the potential of the working electrode such that the rate of electro-oxidation of the reduced form (or electro-reduction of the oxidised form) of the species is diffusion controlled,
  - (3) selecting the spacing between the working electrode and the counter electrode so that reaction products from the counter electrode arrive at the working electrode,
  - (4) determining current as a function of time after application of the potential and prior to achievement of a steady state,
  - (5) estimating the magnitude of the steady state current, and
  - (6) obtaining from the change in current with time and the magnitude of the steady state current, a value indicative of the diffusion coefficient and/or of the concentration of the reduced form (or the oxidised form) of the species.
2. A method according to Feature 1 wherein a steady state concentration profile of electrochemical reaction products is achieved between the working electrode and counter electrode during the period of a test.
  3. A method according to Feature 1 or Feature 2 wherein the electrodes are separated by less than 500  $\mu\text{m}$ .
  4. A method according to any one of the preceding Features wherein the redox species is a mediator and the concentration of the reduced (or oxidised) form of the mediator is indicative of the concentration of an analyte and wherein a measure of the diffusion coefficient of the reduced (or oxidised) form of the mediator is determined as a precursor to the determination of the concentration of the analyte.
  5. A method according to any one of the preceding Features wherein the steady state current is estimated by approximating an initial value for the steady state current, measuring a discrepancy between measured current versus time data and a theoretical curve, and using the degree of discrepancy, if any, to obtain a better estimate of the steady state current.
  6. A method according to any one of Features 1 to 3 wherein the redox species is an analyte.
  7. A method according to any one of Features 1 to 3 wherein the redox species is a mediator.
  8. A method according to any one of the preceding Features wherein the cell comprises a working elec-

trode, a counter electrode and a separate reference electrode.

9. A method according to any one of the preceding Features wherein the spacing between the electrodes is selected such that the steady state current is achieved within a desired time.

10. A method substantially as herein described with reference to any one of the Examples.

11. Apparatus for use in a method according to Feature 1 comprising a porous membrane, a working electrode on one side of the membrane, a counter electrode other side of the membrane, said electrodes together with a zone of the membrane therebetween defining an electrochemical cell, and wherein the membrane extends laterally from the cell to a sample deposition area spaced apart from the cell zone by a distance greater than the thickness of the membrane.

12. Apparatus according to Feature 11, wherein the electrochemical cell contains a reagent.

13. Apparatus according to Feature 11 or Feature 12, wherein the electrochemical cell contains a mediator.

14. Apparatus according to any one of Features 11 to 13, wherein the membrane contains an enzyme intermediate the electrochemical cell and the sample deposition area.

15. Apparatus according to any one of Features 11 to 14, further comprising a pH buffer in the vicinity of the sample deposition area.

16. Apparatus according to Feature 15, further comprising a pH buffer in the vicinity of the working electrode.

17. Apparatus according to Feature 11, comprising a second electrochemical cell zone of the membrane defined by a second working electrode and a second counter/reference electrode on the opposite side of the membrane from the second working electrode.

18. Apparatus according to Feature 17, wherein the second electrochemical cell zone is situated intermediate the first cell zone and the sample deposition or target area.

19. Apparatus according to any one of Features 11 to 18, wherein the uncompressed membrane has a thickness of less than 500  $\mu\text{m}$ .

20. Apparatus according to any one of Features 11 to 19, wherein the working electrode is a metal selected from the group consisting of gold, silver, platinum, palladium, iridium, lead and alloys thereof.

21. Apparatus for determining the concentration of a redox species in an electrochemical cell comprising:

an electrochemical cell having a working electrode and a counter (or counter/reference) electrode,



means for applying an electric potential difference between said electrodes,  
means for measuring the change in current with time, and characterised in that the working electrode is spaced from the counter electrode by less than 500  $\mu\text{m}$ .

22. An electrochemical cell according to Feature 21 wherein the electrodes are spaced from 100 - 200  $\mu\text{m}$  apart.

23. An electrochemical cell according to Feature 21 or Feature 22 wherein the electrodes are facing one another.

24. An electrochemical cell according to any one of Features 21 to 23 wherein the electrodes are of substantially corresponding area.

25. An electrochemical cell according to any one of Features 21 to 24 comprising a working electrode, a counter electrode and a separate reference electrode.

26. An electrochemical cell according to any one of Features 21 to 25 having an effective cell volume of less than 1.5 microlitres.

27. Apparatus substantially as herein described with reference to any one of the Examples.

28. Apparatus according to any one of Features 1 to 18 for use in measuring the concentration of glucose in blood.

29. A method according to any one of Features 1 to 10 when used for determining haematocrit concentration.

#### Claims

1. A hollow electrochemical cell comprising a working electrode (5), a counter electrode (6), and an opening (31) for admitting an analyte to the cell, the working electrode (5) being spaced from the counter electrode (6) by less than 500  $\mu\text{m}$ .
2. A hollow electrochemical cell according to claim 1 wherein the electrodes (5, 6) are spaced from 100 to 200  $\mu\text{m}$  apart.
3. A hollow electrochemical cell according to claim 1 or claim 2, wherein the electrodes (5, 6) are facing one another.
4. A hollow electrochemical cell according to any one of claims 1 to 3, wherein the electrodes (5,6) are of substantially corresponding area.
5. A hollow electrochemical cell according to any one of claims 1 to 4 comprising a working electrode (5), a counter electrode (6), and a separate reference electrode.

6. A hollow electrochemical cell according to any one of claims 1 to 5, having an effective cell volume of less than 1.5 microlitres.

7. A hollow electrochemical cell according to any one of claims 1 to 6, wherein at least one of the electrodes (5,6) comprises a non-metal selected from graphite, carbon mixed with a binder, and carbon-filled plastic.

8. A hollow electrochemical cell according to any one of claims 1 to 6, wherein at least one of the electrodes (5,6) comprises a metal selected from gold, silver, platinum, palladium, iridium, lead and alloys thereof.

9. A hollow electrochemical cell according to any one of claims 1 to 6, wherein at least one of the electrodes (5,6) comprises silver halide.

10. A hollow electrochemical cell according to any one of claims 1 to 9, further comprising a redox species capable of existing in a reduced form or an oxidized form.

11. A hollow electrochemical cell according to claim 10, wherein the redox species is a mediator and a concentration of the reduced or oxidized form of the mediator is indicative of a concentration of an analyte.

12. A hollow electrochemical cell according to claim 11, wherein the analyte comprises glucose.

13. A hollow electrochemical cell according to any one of claims 10 to 12, wherein the counter electrode (6) comprises silver, and wherein the redox species comprises chloride ions contained within a sample.

14. A hollow electrochemical cell according to claim 10 or claim 11, wherein the redox species is selected from chlorine, iron, lead, cadmium, and copper.

15. A hollow electrochemical cell according to any one of claims 1 to 14, wherein the hollow electrochemical cell has at least one wall.

16. A hollow electrochemical cell according to any one of claims 1 to 15, wherein the electrochemical cell further comprises a mediator.

17. A hollow electrochemical cell according to claim 1, wherein the electrochemical cell further comprises a reagent.

18. A hollow electrochemical cell according to claim 17, wherein the reagent comprises glucose oxidase dehydrogenase.

- 19. A glucose sensor comprising a hollow electrochemical cell according to any one of claims 1 to 18.
- 20. Apparatus according to any one of claims 1 to 18 for use in measuring the concentration of glucose in blood.

10

15

20

25

30

35

40

45

50

55

10

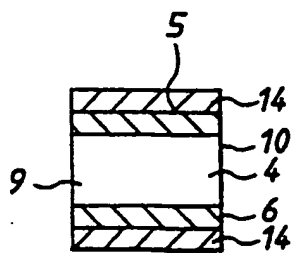
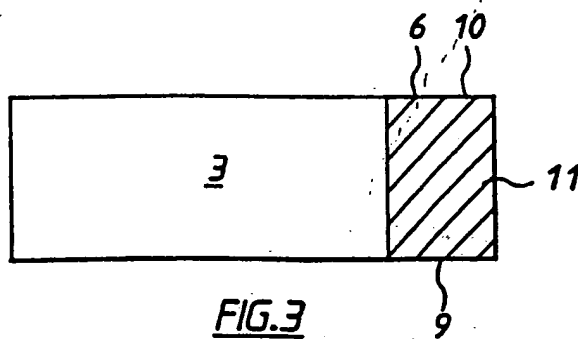
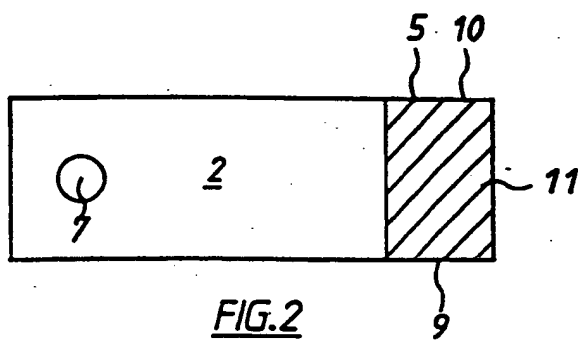
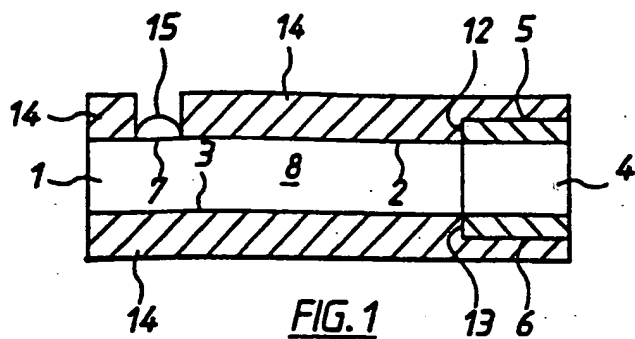

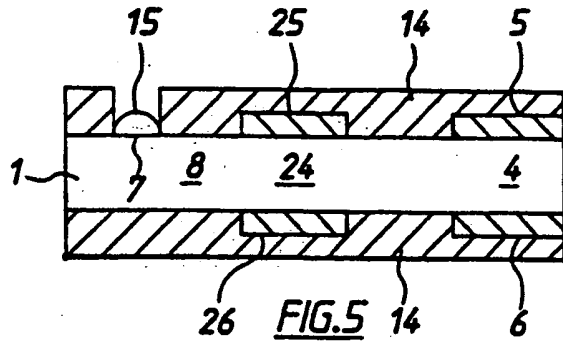

FIG. 5

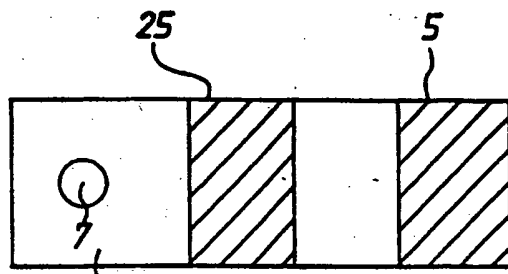

FIG. 6

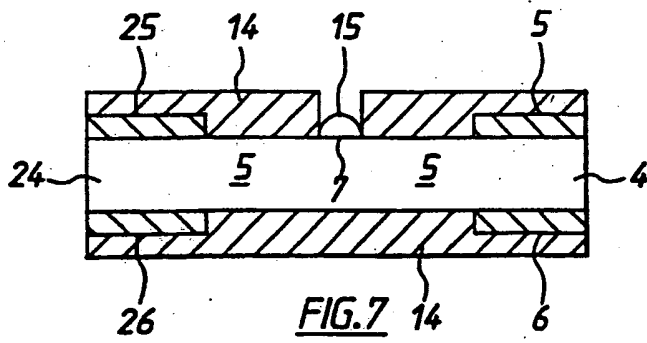

FIG. 7

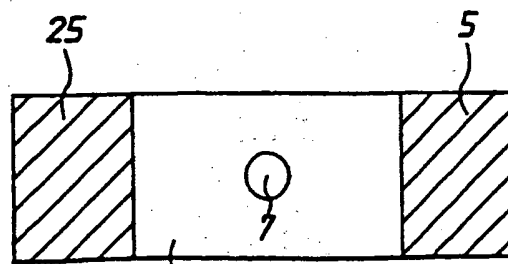

FIG. 8

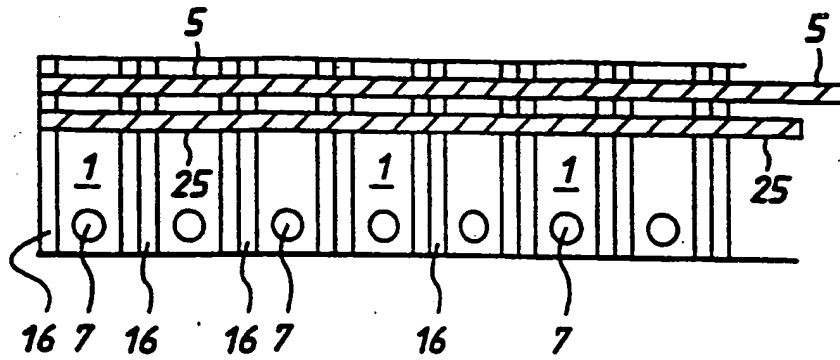

FIG. 9

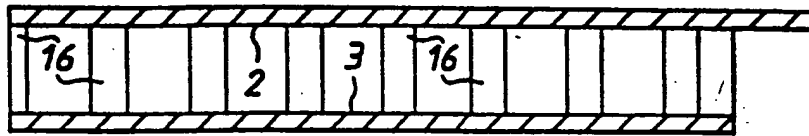

FIG. 10

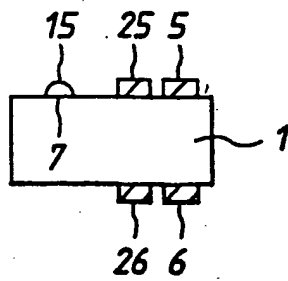

FIG. 11

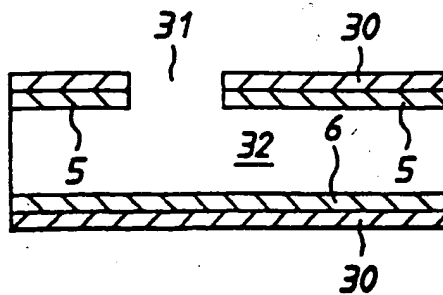

FIG. 12

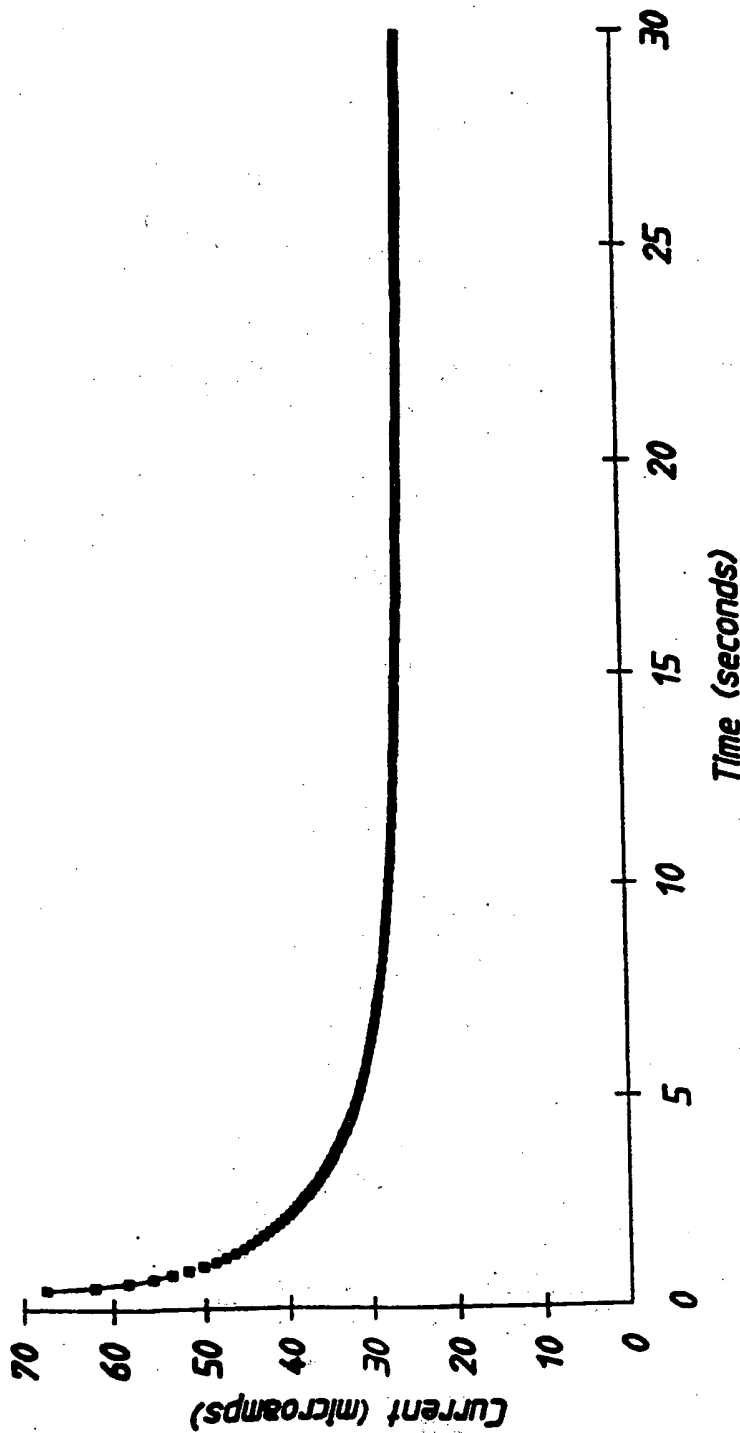

FIG.13

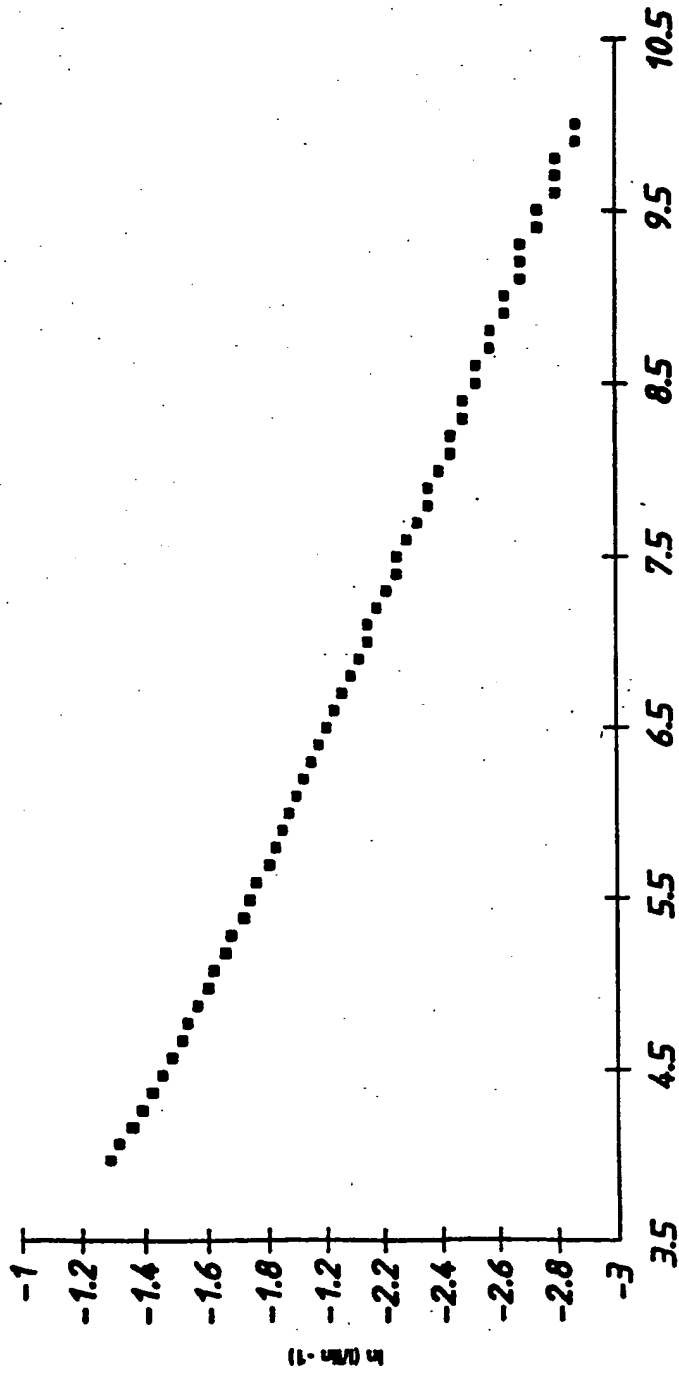

FIG. 14



European Patent  
Office

EUROPEAN SEARCH REPORT

Application Number  
EP 03 00 7604

DOCUMENTS CONSIDERED TO BE RELEVANT			
Category	Citation of document with indication, where appropriate, of relevant passages	Relevant to claim	CLASSIFICATION OF THE APPLICATION (Int.Cl.7)
X	US 5 399 256 A (BOHS C E ET AL) 21 March 1995 (1995-03-21)	1-3, 5-10,14, 15	G01N27/49 C12Q1/00
Y	* column 2, line 32 - column 16, line 4; figures 4,5 *	4,11-13, 16-20	
Y	---		
Y	WO 94 29731 A (BOEHRINGER MANNHEIM) 22 December 1994 (1994-12-22)	4,13	
A	* page 3, line 22 - page 9, line 26; figure 2 *	1,5,8, 10,11, 15,16	
Y	---		
Y	US 5 120 420 A (OHTANI MAYUMI ET AL) 9 June 1992 (1992-06-09)	11,12, 16-20	
A	* column 4, line 50 - column 5, line 18 * * column 6, line 29 - line 45 *	1,8,9	
	---		
X	US 4 554 064 A (MCCLINTOCK S A ET AL) 19 November 1985 (1985-11-19) * column 2, line 23 - column 3, line 65; figure *	1,3,5-7, 10,15	G01N
X	---		
X	JP 05 002007 A (NIPPON TELEGRAPH & TELEPHONE) 8 January 1993 (1993-01-08) * paragraph [0009] - paragraph [0011]; figures 2,3 * -& PATENT ABSTRACTS OF JAPAN vol. 17, no. 258 (P-1540), 20 May 1993 (1993-05-20) & JP 05 002007 A (...) * abstract *	1,4,5,8, 10,11, 15,16	
	---		
			TECHNICAL FIELDS SEARCHED (Int.Cl.7)
The present search report has been drawn up for all claims			
Place of search <b>MUNICH</b>		Date of completion of the search <b>19 May 2003</b>	Examiner <b>Johnson, K</b>
<b>CATEGORY OF CITED DOCUMENTS</b> X : particularly relevant if taken alone Y : particularly relevant if combined with another document of the same category A : technological background O : non-written disclosure P : intermediate document		T : theory or principle underlying the invention E : earlier patent document, but published on, or after the filing date D : document cited in the application L : document cited for other reasons & : member of the same patent family, corresponding document	

EPO FORM 1503 03 82 (P/AC/01)





European Patent  
Office

EUROPEAN SEARCH REPORT

Application Number  
EP 03 00 7604

DOCUMENTS CONSIDERED TO BE RELEVANT			
Category	Citation of document with indication, where appropriate, of relevant passages	Relevant to claim	CLASSIFICATION OF THE APPLICATION (Int.Cl.7)
A	<p>JP 04 343065 A (NGK SPARK PLUG COMPANY) 30 November 1992 (1992-11-30)</p> <p>* figures 3,6 * -&amp; PATENT ABSTRACTS OF JAPAN vol. 17, no. 194 (P-1522), 15 April 1993 (1993-04-15) &amp; JP 04 343065 A (...) * abstract *</p> <p style="text-align: center;">-----</p>	1,3,4,8, 10-12, 15,20	
			TECHNICAL FIELDS SEARCHED (Int.Cl.7)
The present search report has been drawn up for all claims			
Place of search <b>MUNICH</b>		Date of completion of the search <b>19 May 2003</b>	Examiner <b>Johnson, K</b>
<p><b>CATEGORY OF CITED DOCUMENTS</b></p> <p>X : particularly relevant if taken alone Y : particularly relevant if combined with another document of the same category A : technological background O : non-written disclosure P : intermediate document</p>		<p>T : theory or principle underlying the invention E : earlier patent document, but published on, or after the filing date D : document cited in the application L : document cited for other reasons</p> <p>----- &amp; : member of the same patent family, corresponding document</p>	

EPO FORM 1503 03.02 (P04001)

**ANNEX TO THE EUROPEAN SEARCH REPORT  
ON EUROPEAN PATENT APPLICATION NO.**

EP 03 00 7604

This annex lists the patent family members relating to the patent documents cited in the above-mentioned European search report. The members are as contained in the European Patent Office EDP file on the European Patent Office is in no way liable for these particulars which are merely given for the purpose of information.

19-05-2003

Patent document cited in search report		Publication date	Patent family member(s)	Publication date
US 5399256	A	21-03-1995	NONE	
WO 9429731	A	22-12-1994	US 5385846 A CA 2140903 A1 DE 69422687 D1 DE 69422687 T2 EP 0653068 A1 ES 2142946 T3 JP 8500190 T JP 3369183 B2 WO 9429731 A1	31-01-1995 04-12-1994 24-02-2000 29-06-2000 17-05-1995 01-05-2000 09-01-1996 20-01-2003 22-12-1994
US 5120420	A	09-06-1992	JP 1253648 A JP 2502665 B2 JP 2062952 A JP 2502666 B2 JP 1291153 A JP 1932654 C JP 6058338 B DE 68924026 D1 DE 68924026 T2 EP 0359831 A1 WO 8909397 A1	09-10-1989 29-05-1996 02-03-1990 29-05-1996 22-11-1989 26-05-1995 03-08-1994 05-10-1995 21-03-1996 28-03-1990 05-10-1989
US 4554064	A	19-11-1985	CA 1216894 A1	20-01-1987
JP 05002007	A	08-01-1993	JP 2992603 B2	20-12-1999
JP 04343065	A	30-11-1992	NONE	

EPO FORM P069

For more details about this annex : see Official Journal of the European Patent Office, No. 12/82

**This Page is Inserted by IFW Indexing and Scanning  
Operations and is not part of the Official Record**

**BEST AVAILABLE IMAGES**

Defective images within this document are accurate representations of the original documents submitted by the applicant.

Defects in the images include but are not limited to the items checked:

- BLACK BORDERS**
- IMAGE CUT OFF AT TOP, BOTTOM OR SIDES**
- FADED TEXT OR DRAWING**
- BLURRED OR ILLEGIBLE TEXT OR DRAWING**
- SKEWED/SLANTED IMAGES**
- COLOR OR BLACK AND WHITE PHOTOGRAPHS**
- GRAY SCALE DOCUMENTS**
- LINES OR MARKS ON ORIGINAL DOCUMENT**
- REFERENCE(S) OR EXHIBIT(S) SUBMITTED ARE POOR QUALITY**
- OTHER:** \_\_\_\_\_

**IMAGES ARE BEST AVAILABLE COPY.**

**As rescanning these documents will not correct the image problems checked, please do not report these problems to the IFW Image Problem Mailbox.**

**This Page Blank (uspto)**